

BZ 145

Item no.: 1450000

theben

Time and light control
Hour counters

Description

- Hour counter with synchronous motor drive
- Built in distributor device with quick fastening for 35 mm profile rails (DIN EN 60 715)
- Top mounting with additional terminal box cover plate, sealable
- Control panel installation with assembly kit possible
- Contact protection to comply with accident prevention regulation BGV A3
- Captive screw terminals



Technical data

	BZ 145
Operating voltage	230 V AC
Frequency	50 Hz
Width	2 modules
Installation type	DIN rail
Size front plate	35 x 45 mm
Size of Installation section	

	BZ 145
Counting range	99999.9 h
Type of protection	IP 20
Protection class	II according to EN 60 335-1
Ambient temperature	-10°C ... 70°C

Subject to technical changes and misprints

additional information at: www.theben.de/product/1450000

The load data are determined with exemplary selected illuminants and are therefore typical data due to the large number of available products.

BZ 145

Item no.: 1450000



Connection example

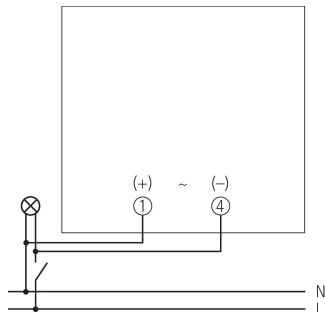

Scale drawings

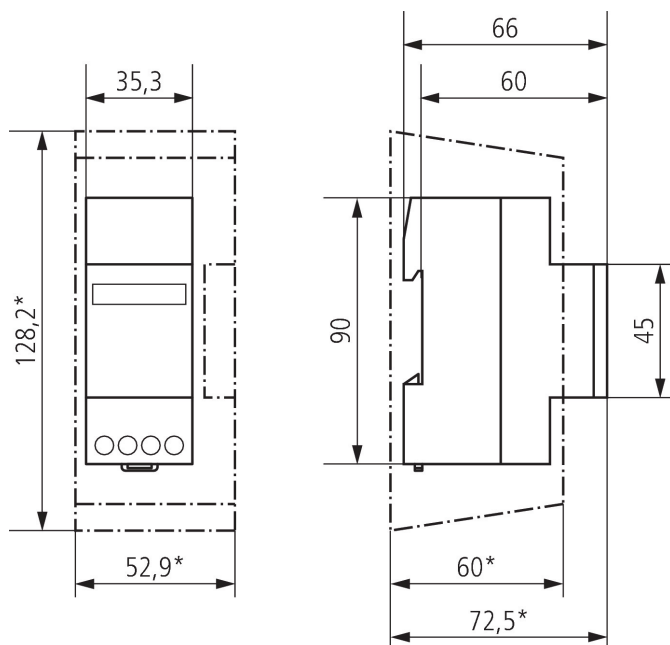

Subject to technical changes and misprints

additional information at: www.theben.de/product/1450000

The load data are determined with exemplary selected illuminants and are therefore typical data due to the large number of available products.